

Richard A. Pride  
NASA Langley Research Center  
Hampton, Virginia, USA

### Abstract

Interim results from a number of ongoing, long-term environmental effects programs for composite materials are reported. The flight service experience is evaluated for 142 composite aircraft components after more than five years and one million successful component flight hours. Ground-based outdoor exposures of composite material coupons after 3 years of exposure at five sites have reached equilibrium levels of moisture pickup which are predictable. Solar ultraviolet-induced material loss is discussed for these same exposures. No significant degradation has been observed in residual strength for either stressed or unstressed specimens, or for exposures to aviation fuels and fluids.

### Introduction

The influence of the operational environment on the behavior of composite materials and aircraft components fabricated with these composite materials is a subject of continuing concern both for the aircraft manufacturer and the airline operator. The structural weight savings and the potential for manufacturing cost savings have been well documented in a number of composite hardware development programs in recent years. These advantages have left the question of long-term environmental durability for composites as the major undetermined issue for widespread acceptance and application.

This paper reports on the interim results from a number of ongoing, long-term, environmental effects programs. The flight service experience to date of composite components is evaluated. In addition, the influence of a number of worldwide, ground-based outdoor exposures on the physical and mechanical properties of six composite materials is discussed. In particular, the current extent of the ultraviolet surface degradation and the moisture gained by diffusion is shown. Finally, comparisons are made of the combined effects of stressed exposure in the outdoor environment with unstressed exposure, and results of exposures to aviation fuels and fluids are presented.

### Flight Service of Composite Components

A number of composite structural components have been designed, manufactured, tested, and placed in operational service on a variety of aircraft. This operational flight service is monitored periodically to evaluate the long-term experience with composite durability. The types of aircraft and composite components are shown in figure 1. The L-1011 application is six fuselage fairing panels involving two types of Kevlar-49 epoxy composite on each of three airplanes<sup>1</sup>. Three graphite-epoxy material systems are used for the spoilers on 27 Boeing 737 airplanes<sup>2</sup>. A fourth graphite-epoxy material is used in the upper, aft

rudder segment on ten DC-10 airplanes<sup>3</sup>, and boron-aluminum composite skin is used in a panel on the aft pylon adjacent to the engine on three DC-10 airplanes<sup>4</sup>. Boron-epoxy is used as a selective reinforcement in the aluminum aft fuselage, or tail cone, of an Army CH-54B helicopter<sup>5</sup> and in the aluminum center wing box of two Air Force C-130 transports<sup>6</sup>.

The status of these composite structural components in the Langley flight service program, as of January 1, 1978, is given in table I. The boron-epoxy composite in the CH-54B helicopter tail cone has been in service for the longest calendar time, six years, but it has been flown very little compared to the other types of aircraft. The Kevlar-49 epoxy in the L-1011 fairing panels has accumulated the greatest single component flight time, 13 138 flight hours in five years of service. The graphite-epoxy in the 108 spoilers on the 737 airplanes has accumulated the greatest total component flight hours, 921 600 in four and one-half years. The graphite-epoxy in one of the DC-10 upper aft rudders has been acquiring flight service time at the greatest rate of any of the components in the table, a rate of 400 hours per month or about 13 hours per day. Overall the 142 composite components have accumulated in excess of one million component flight hours in service around the world with 17 operators. Each of these composite components has been inspected at least annually by the manufacturer, under terms of the NASA contracts. There have been no significant incidents or damage detected in any of these flight components. Maintenance has been reported as less than that required on similar standard, production parts.

### Materials

The composite materials used for these exposure tests were combinations of graphite or aramid fibers and epoxy resins. The specific materials used were

Thornel 300 graphite fibers manufactured by Union Carbide Corporation

AS graphite fibers, manufactured by Hercules Incorporated

Kevlar 49 aramid fibers manufactured by E. I. du Pont de Nemours & Co., Inc.

5208 and 5209 epoxy resins, manufactured by Narmco Materials, a subsidiary of Celanese Corporation

2544 epoxy resin, manufactured by Union Carbide Corporation

3501 epoxy resin, manufactured by Hercules Incorporated

F155 and F161 epoxy resins, manufactured by Hexcel Corporation

Identification of commercial products in this report is to adequately describe the materials and does not constitute official endorsement, expressed or implied, of such products or manufacturers by the National Aeronautics and Space Administration.

#### Composite Spoilers

The large number (108) of replicate spoilers with graphite-epoxy skins allows a program of planned retrievals from flight service without seriously impairing the total exposure. Six spoilers are selected at random for removal annually, two of each of the three material systems. These spoilers are shipped to the Boeing Company where they are nondestructively inspected by ultrasonic C-scan. The C-scan record is compared with similar records made at the completion of manufacturing. To date, no significant differences have been observed. Three of the six spoilers are then selected for destructive testing and the remaining three are returned to flight service.

For destructive testing the spoilers are mounted in the same static test jig as was used for the initial airworthiness certification tests<sup>2</sup>. A distributed load is applied to the outer surface of the spoiler, simulating aerodynamic loads, and the magnitude is increased until failure occurs. Results of these residual static strength tests on the graphite-epoxy spoilers are shown in figure 2. The residual strengths for each material system have been divided by the failure strength of the initial certification test for each material, and the results are presented nondimensionally as a function of the time in service. A scatter band for strength tests of 16 new replicate spoilers manufactured with the T300-5209 graphite-epoxy material has been superimposed on the individual tests of spoilers removed from service. In four years of service, the scatter in strength for the individual spoilers generally falls within the width of the new spoiler strength scatter band; an indication of essentially no degradation in strength.

After several years of unsuccessfully attempting to determine the moisture absorbed by the graphite-epoxy spoilers in service, a technique of cutting plugs from near the trailing edge was developed (fig. 3). The eight rectangular areas shown with an arrow in the center of each represent the whiffletree loading areas for static strength tests. Since failures always have initiated near the leading edge at one of the center hinges, it has been determined that three plugs of 6.4 cm (2.5 in.) diameter could be cut from the region behind the loading areas without influencing the failure load. These plugs, which consist of aluminum honeycomb core, two graphite-epoxy face sheets, two layers of epoxy film adhesive and two exterior coats of polyurethane paint, have about 90 percent of their weight in the composite faces, including the paint and adhesive. A good determination of the moisture level in the spoiler can be made by drying the plug and noting the weight change. After three years of service with Lufthansa Airlines in Germany, plugs taken from a T300-5209 graphite-epoxy spoiler indicated a moisture content of 0.64 percent, based on the composite weight.

Somewhat greater significance may be attached to this value when corrections have been determined for relative differences in equilibrium moisture levels in the paint, the composite matrix, and the adhesive.

Subsequent to the introduction into flight service of the graphite-epoxy-skinned spoilers, a development program was undertaken for an all-composite spoiler which included glass-epoxy honeycomb core, molded graphite-epoxy hinge fittings and leading edge spar, and thermoplastic graphite-poly-sulfone skins. It was recognized that the poly-sulfone matrix had an environmental sensitivity to phosphate-ester-based hydraulic fluids, and the laboratory testing demonstrated this in elevated temperature, stressed immersions. However, based on the room temperature experience it was believed that the material could be successfully used in flight components with only minor, intermittent exposures to hydraulic fluid leakage from the spoiler actuators. Twelve of these spoilers were fabricated and placed in service on six of the aircraft that were flying graphite-epoxy spoilers. After six months of operational flight service the two spoilers installed on Aloha Airlines were reported to have developed significant delamination of the lower surface skin directly aft of the actuator attachment fitting (fig. 4). Within a month a third spoiler was reported as starting to experience delamination, so it was decided to remove all the remaining graphite-poly-sulfone spoilers. A closeup view of the delaminated area is shown in the photograph in figure 5. This experience demonstrated the difficulty of performing adequate laboratory accelerated environmental testing and provided a good example of the necessity for flight service evaluation.

There have been several instances in which the graphite-epoxy spoilers have received damage in service sufficient to require repairs. Examples of these are illustrated in figure 6. On this program, damaged spoilers are removed from the aircraft and returned to The Boeing Company for repair. Repairs are made by cutting out the damaged area, replacing honeycomb core as needed, and replacing graphite-epoxy plies on a one-for-one basis with each ply lapped over the underlying one by about 6 mm (0.25 in.). One piece of adhesive film is placed under the patch assembly and the built-up patch is cured and bonded in one cycle in an autoclave with the spoiler supported in its original assembly tooling<sup>7</sup>. The repaired spoiler is ultrasonically inspected and returned to flight service with the airline which had previously used it.

#### Worldwide Ground-based Outdoor Exposure

As a parallel part of the flight service exposures of composite components, a number of replicate mechanical property specimens have been manufactured from the same composite material systems used in the components. These specimens have been mounted in racks which are deployed on rooftops of airline buildings at a number of airports around the world so as to receive maximum exposure to the airport ground environment. The location of six of the exposure sites is shown on the map of the world in figure 7. Each of these locations has an exposure rack with unstressed specimens as indicated in figure 8. Each of the five panels mounted in

the rack contains triplicate specimens of four graphite-epoxies, one graphite-polysulfone, and two Kevlar-49 epoxies in short beam interlaminar shear, flexure and compression configurations. After one year and three years of exposure a panel is removed from each rack and shipped to Langley Research Center for specimen testing and evaluation.

In addition to the unstressed exposures, three racks containing stressed tensile specimens (fig.9) are also deployed, one each at San Francisco, Seattle, and Langley. Individual specimens are mounted in fixtures which apply a constant load through a compressed helical spring. Unstressed tensile specimens are also placed in these same racks for comparison.

When specimens are removed and shipped to Langley periodically, they are weighed to determine weight changes associated with moisture absorption and weathering. An example of the specimen weight changes with exposure time is shown in figure 10 for a thin graphite-epoxy specimen in the unstressed rack at Langley. The solid curve in the center of the figure drawn through the circular test points is the record of the repeated weighings. The specimen initially gained weight and then began to gradually lose weight as a result of the combined effects of moisture and solar ultraviolet exposure. The exposure of this specimen was terminated after 140 days and the specimen was then dried to a fully dry condition. The weight change associated with this drying indicated the actual measured moisture level in the specimen at 140 days. Comparing the fully dry weight to the initial fully dry weight showed the measured ultraviolet effect of a weight loss after 140 days. Since the ultraviolet effect is a loss from the exposed specimen surface, it is assumed to be linear with exposure time. Corrections can then be calculated for the measured weights at intermediate times, and an interpolated moisture curve can then be plotted as shown by the upper dashed line in figure 10. This curve appears to have reached an equilibrium level of moisture absorption between 0.6 and 0.7 percent. The small fluctuations correspond to changes in the daily levels of relative humidity.

The results of fully drying the flexure specimens from five exposure sites after three years of exposure provided a pattern of weight losses due to ultraviolet exposure as shown in figure 11. For any given material, the weight losses are greater for exposure sites closest to the equator. Variations in the epoxy matrices for the different material systems seem to provide a greater variation in weight loss than changes in exposure site latitude. In all cases the specimens were exposed in an as-laminated condition without any protective coating. The weight losses in three years time correspond to less than 25 percent of one ply thickness.

Scanning electron micrographs of two areas on one of the T300-5209 graphite-epoxy specimens exposed at the Honolulu site are shown in figure 12. The left-hand area was shielded from the solar ultraviolet by the specimen mounting clamp on the exposure rack. The magnified view is essentially the original as-laminated surface, which is entirely epoxy. The right-hand area was typical of the unshielded portion of the same specimen. In this

area the epoxy matrix has been removed by the ultraviolet weathering process, exposing a layer of individual graphite fibers. Although the effect looks bad, it really is quite superficial in three years time and it can be prevented by painting the exposed specimen surface.

The amount of moisture absorbed by the various composite material systems is shown in figure 13. These results represent the determinations made on flexure specimens after their worldwide outdoor exposures for times up to three years. The weight gains shown have been corrected for the ultraviolet weight losses as described previously for figures 10 and 11. The scatter bands indicated for the three-year exposures contain all the data for triplicate specimens and five exposure sites. In general there is no separation of individual sites by the magnitude of absorbed moisture. The largest variable appears to be the type of epoxy matrix used in the composites. Even the Kevlar-epoxy values are in the same range as one of the graphite-epoxies. Data for T300-5208 graphite-epoxy is only shown for a 1.7-year exposure because the specimens which were made as a part of the graphite-epoxy rudder flight service program were not available to be deployed in the exposure rack panels until 1.3 years after the other specimens were deployed. However, the absorbed moisture for the T300-5208 is essentially the same as for the T300-5209 material, and both appear to be at an equilibrium level of about 0.5 percent of the laminate weight.

A comparison of the measured moisture contents for both T300-5208 and T300-5209 materials with predicted moisture contents for a 12-ply laminate of T300-5208 graphite-epoxy is shown in figure 14. The predicted moisture contents are based on calculations using the Fickian diffusion equations with varying inputs for relative humidity and temperature<sup>8</sup>. These varying inputs are taken directly from tape recordings of the weather at Langley Research Center. The predicted curve marked "No Solar" was calculated assuming that the temperature of the specimen was the same as that of the ambient air. This is a reasonable assumption for specimens exposed in shade; however, if the specimens are exposed to the Sun, they will be heated to temperatures well above the ambient air temperature on clear, sunny days. This will increase the rate of moisture diffusion and, more importantly, decrease the local relative humidity at the surface of the specimens. Inclusion of these effects in the calculations results in the lower predicted curve marked "Solar". The weather data for the year 1962 were used repetitively in the calculations, starting at the first of October to correspond with the initial deployment of the exposure racks and specimens. The experimental data points at 1, 1.7, and 3 years are taken from the overall worldwide exposure data previously discussed in figure 13 for T300-5208 and T300-5209 graphite-epoxies. The correlation between prediction and experiment is good.

The observed loss of material from ultraviolet exposure and pickup of moisture from the relative humidity leads to a concern for the effect on residual mechanical properties. Figure 15 shows the results of flexure strength tests performed after various exposure times at all of the worldwide exposure sites for six composite materials. The data are shown in nondimensional form obtained by dividing residual strengths by the initial as-

laminated strengths. The width of the scatter band for strength is largely a function of the scatter in triplicate tests from various exposure sites. However, it is not sufficiently greater than the scatter in the initial replicate tests to justify any conclusions. It is evident that for three years of outdoor ground-based unstressed exposure there has been no indication of degradation in flexure strength. Similar conclusions can be drawn from results of the short beam interlaminar shear and the compression tests also, after three years of unstressed outdoor exposure.

To consider the possible influence of constant stress during the outdoor exposure, three sets of tensile specimens have been included in the program. The first set consists of T300-5209 graphite-epoxy material laminated at  $+45^\circ$  ply orientation and stressed during exposure at 25 percent of the initial ultimate strength. Exposure and residual strength testing have been conducted in the Seattle, Washington area by The Boeing Company under NASA contract. Results shown in figure 16 indicate essentially no difference between stressed and unstressed exposure and no degradation in tensile strength for up to three years of exposure. The second and third sets of tensile specimens are T300-5208 graphite-epoxy material laminated in a  $[0^\circ, +45^\circ, 90^\circ]$  quasi-isotropic ply orientation and stressed during exposure at 40 percent of the initial ultimate strength. Exposure sites for these are located at the San Francisco airport and at Langley. Specimens have been retrieved and tested at Langley after one and three years exposure. The results shown in figure 17 indicate about the same amount of scatter as shown previously for the flexure strengths and indicate essentially no difference between stressed and unstressed exposures and no degradation in tensile strength.

Another type of environmental exposure includes the interaction of composite materials with extended exposure to aircraft fuels and hydraulic fluids. Under NASA contract The Boeing Company has conducted a series of exposures of several composite materials in JP-4 jet fuel, a commercial aviation phosphate-ester hydraulic fluid, a fuel-and-water mixture, and a fuel-and-air cyclic environment. All exposures are outdoors in an unheated shed in the Seattle area. Short beam interlaminar shear and tensile specimens are being exposed. Typical results are shown in figure 18 for T300-5209 graphite-epoxy material laminated at a  $+45^\circ$  ply orientation. The data indicate no degradation in tensile strength for up to three years exposure in any of the above environments.

#### Conclusions

Interim results from a number of programs relating to the long-term environmental durability of composite materials in the commercial airline operational environment have been presented and the following conclusions can be drawn:

1. More than five years and 1 000 000 component flight hours of successful flight service evaluation have been achieved for 142 composite components.

2. Residual strength tests of graphite-epoxy

spoilers removed from service annually have shown no significant effects in four years.

3. Ground-based outdoor exposures of composite material coupons after 3 years of exposure have reached equilibrium levels of moisture pickup ranging from 0.5 to 2.1 percent of the composite laminate weight, and have produced a solar ultraviolet-induced material loss for unprotected epoxy matrix specimens which is less than 25 percent of one ply. Specific levels of moisture pickup are predictable and are dependent on the particular material system.

4. No significant degradation has been observed on residual strength tests of 3-year outdoor exposures worldwide for interlaminar shear, flexure and compression specimens; for stressed and unstressed tensile specimens; and for exposures to aviation fuels and fluids.

#### References

1. Wooley, John H.; Paschal, Dale R.; and Crilly, Eugene R.: Flight Service Evaluation of PRD-49/Epoxy Composite Panels in Wide-Bodied Commercial Transport Aircraft. Contract No. NAS 1-11621, Lockheed-California Co., Mar. 1973. (Available as NASA CR-112250.)
2. Stoecklin, Robert L.: Development, Manufacturing, and Test of Graphite-Epoxy Composite Spoilers for Flight Service on 737 Transport Aircraft. NASA CR-132682, 1976.
3. Lehman, George M.; et al: Advanced Composite Rudders for DC-10 Aircraft - Design, Manufacturing, and Ground Tests. NASA CR-145068, [1976].
4. Elliott, S. Y.: Boron-Aluminum Skins for the DC-10 Aft Pylon - Final Report. NASA CR-132645, 1975.
5. Welge, R. T.: Application of Boron/Epoxy Reinforced Aluminum Stringers and Boron/Epoxy Skid Gear for the CH54B Helicopter Tail Cone. Phase II: Fabrication, Inspection and Flight Test. Contract No. NAS 1-10459, Sikorsky Aircraft, United Aircraft Corp., July 1972. (Available as NASA CR-112101.)
6. Harvill, W. E.; and Kizer, J. A.: Program for Establishing Long-Time Flight Service Performance of Composite Materials in the Center Wing Structure of C-130 Aircraft. Phase IV - Ground/Flight Acceptance Tests. NASA CR-145043, 1976.
7. Stoecklin, Robert L.: 737 Graphite Composite Flight Spoiler Flight Service Evaluation. NASA CR-145207, 1977.
8. Unnam, J.; and Tenney, D. R.: Analytical Prediction of Moisture Absorption/Desorption in Resin Matrix Composites Exposed to Aircraft Environments. Volume A - Structures and Materials, AIAA/ASME 18th Structures, Structural Dynamics & Materials Conference, Mar. 1977, pp. 227-235.

TABLE 1  
LANGLEY COMPOSITES FLIGHT SERVICE PROGRAM

AIRCRAFT, COMPONENT	TOTAL COMPONENTS	START OF FLIGHT SERVICE	CUMULATIVE FLIGHT HOURS	
			HIGH TIME AIRCRAFT	TOTAL COMPONENT
CH-54B TAIL CONE	1	MARCH 1972	924	924
L-1011 FAIRING PANELS	18	JANUARY 1973	13,138	186,600
737 SPOILER	108	JULY 1973	11,315	921,600
C-130 CENTER WING BOX	2	OCTOBER 1974	2,394	4,800
DC-10 AFT PYLON SKIN	3	AUGUST 1975	6,516	19,400
DC-10 UPPER AFT RUDDER	10	APRIL 1976	6,600	27,800
GRAND TOTAL	142			1,161,100

T300-5209 GRAPHITE-EPOXY AFTER THREE YEARS SERVICE WITH LUFTHANSA  
RESIDUAL MOISTURE  
0.63 PERCENT  
0.66  
0.62 } AV = 0.64 PERCENT

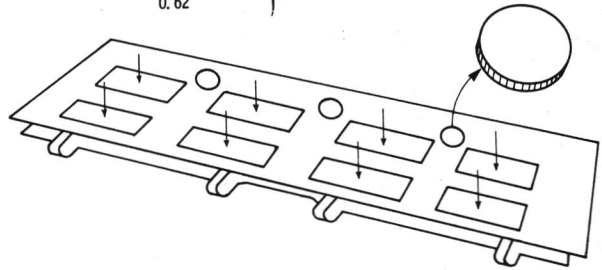

Figure 3.- Spoiler moisture levels determined from plugs.

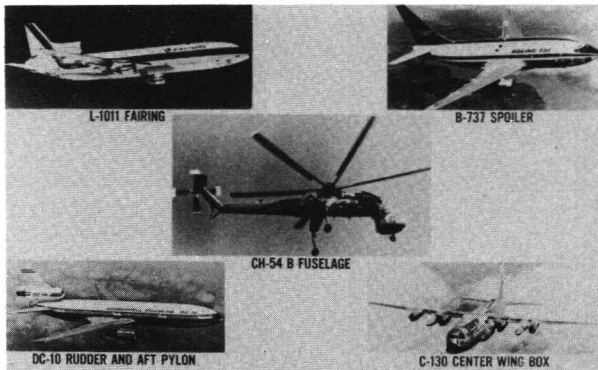

Figure 1.- Flight service evaluation of composite structural components.

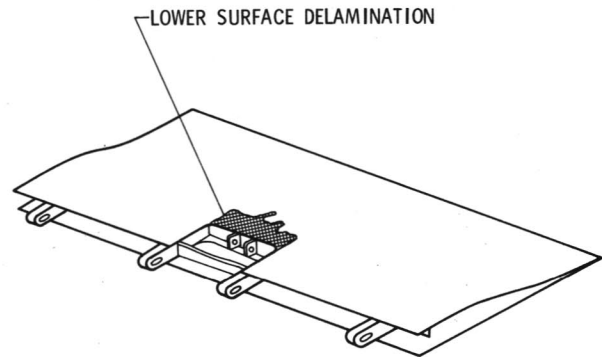

Figure 4.- General area of spoiler delamination.

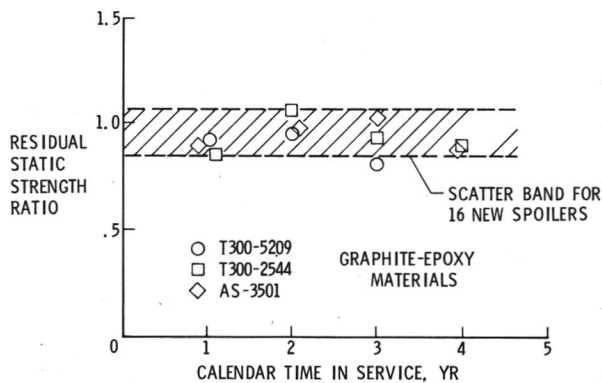

Figure 2.- Residual static strength of graphite-epoxy spoilers.

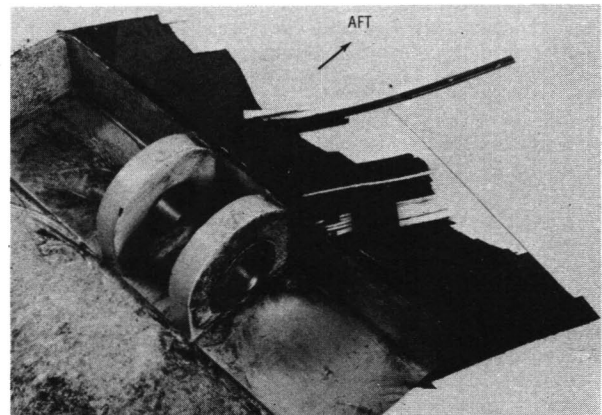

Figure 5.- Delamination of spoiler cover due to hydraulic fluid attack.

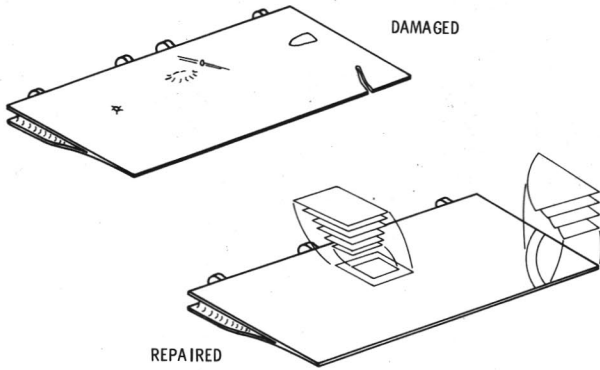

Figure 6.- Graphite-epoxy spoiler repair techniques.



Figure 9.- Stressed exposure rack.



Figure 7.- Distribution of environmental exposure racks.

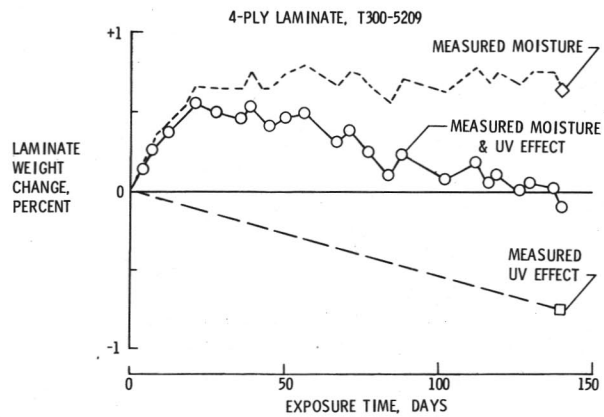

Figure 10.- Weight change in outdoor exposure; 4-ply laminate, T300-5209.

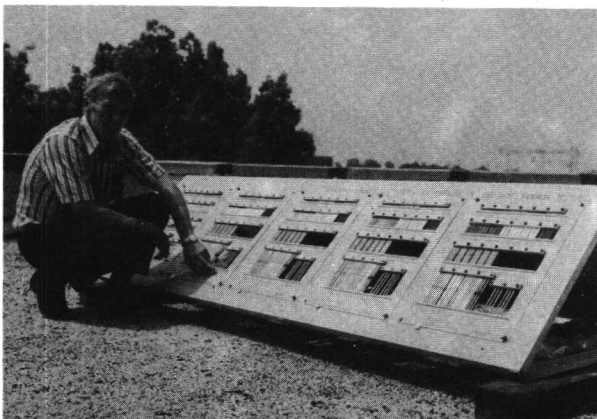

Figure 8.- Unstressed exposure rack.

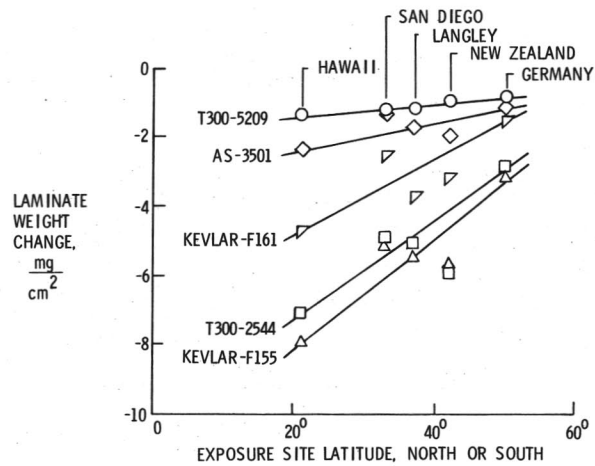

Figure 11.- Weight loss from three-years outdoor ultraviolet exposure.

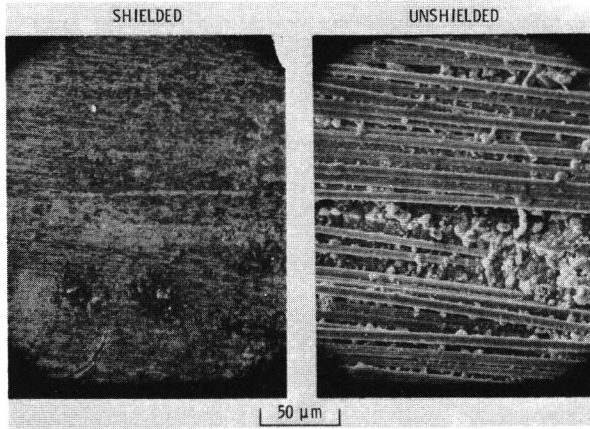

Figure 12.- Graphite-epoxy surface degradation; 3-years outdoor exposure.

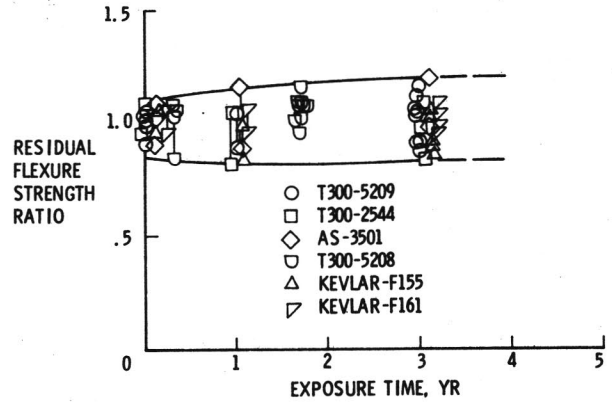

Figure 15.- Residual flexure strength after worldwide exposure.

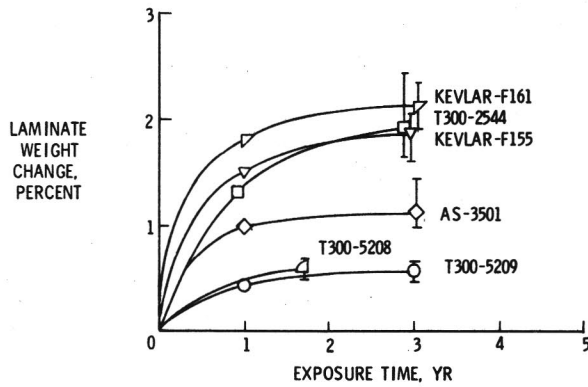

Figure 13.- Moisture pickup after worldwide exposures.

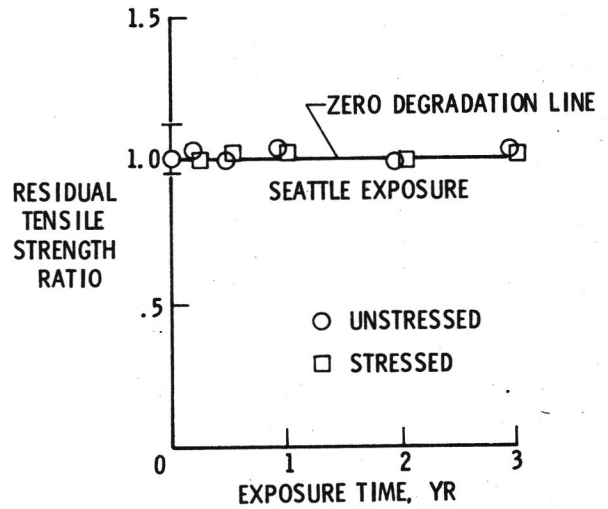

Figure 16.- Residual tensile strength after sustained stress outdoor exposures; T300-5209,  $\pm 45^\circ$  laminate stressed at 25 percent ultimate.

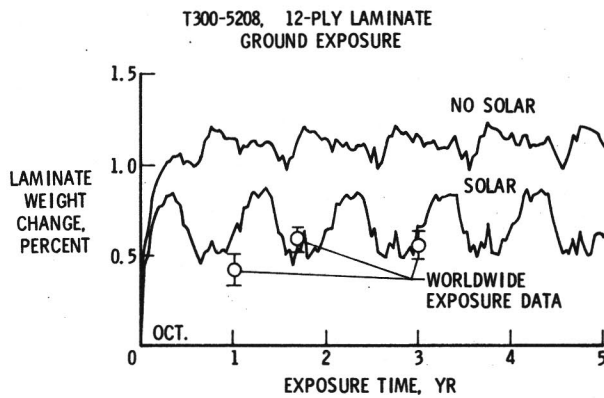

Figure 14.- Comparison of predicted and measured moisture contents; T300-5208, 12-ply laminate; ground exposure.

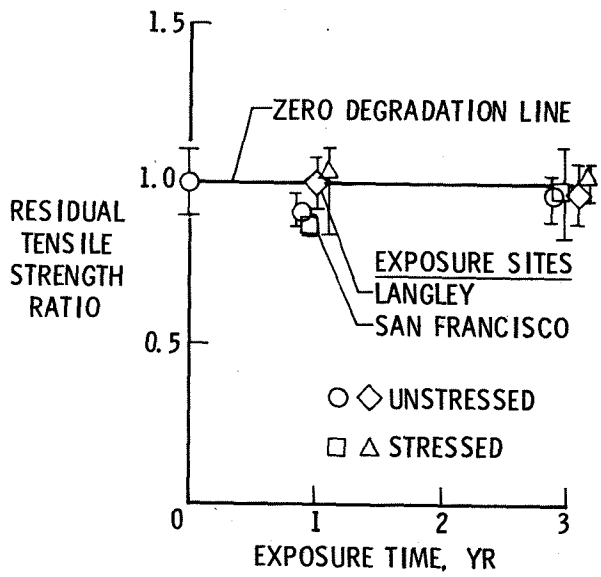

Figure 17.- Residual tensile strength after sustained stress outdoor exposures; T300-5208, (0°, +45°, 90°) laminate stressed at 40 percent ultimate.

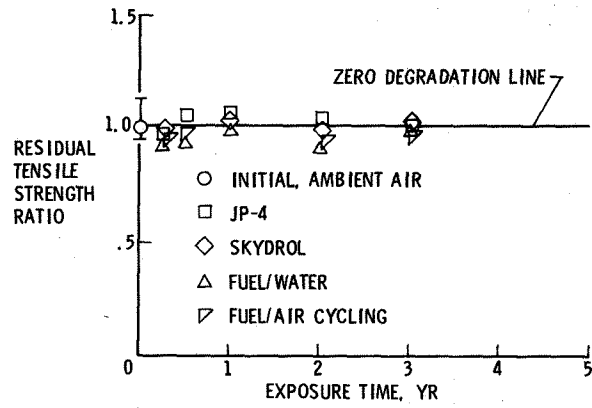

Figure 18.- Effect of fuels and fluids on strength; T300-5209, +45° tensile specimens.